

Frameless Allwood Construction

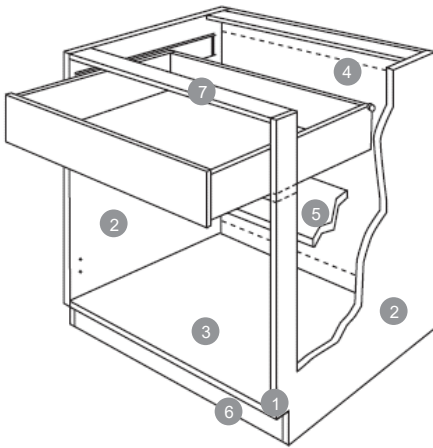
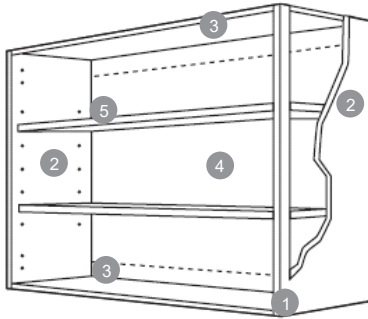

- 1 **BOX CONSTRUCTION** – 5/8" industrial grade plywood conforming to ANSI 208.1 and CARB Phase 2, faced with both thermally fused melamine & polyurethane coated overlays (for doors & drawer fronts, and for end panels respectively). Front face of cabinet edgebanded with 0.5mm PVC in door matching colors. Nailers, Stretchers, and Toe Kicks have a 2-dowel application, increasing the lateral strength of the overall cabinet.
- 2 **END PANELS** – polyurethane-coated material, matching the color of doors and drawer fronts. End Panels are bore and dowel with glue joinery. Exterior matches door and drawer front color. Interior finish is light maple laminate on stained products; painted, thermofoil, and thermofused melamine products will come with white laminate interiors. End panels are not textured.
- 3 **TOP/BOTTOM PANELS** – 5/8" industrial grade plywood conforming to ANSI 208.1 and CARB Phase 2. Exposed exterior panels faced with laminate matching the color of doors and drawer fronts.
- 4 **BACK PANEL** – 1/8" (3mm) thick hardboard fully captured back panel in dado glued to maintain squareness and structural rigidity.
- 5 **SHELVES** – 5/8" thick plywood with plamine on both sides including matching edgeband for front face. Shelves are adjustable in all wall and fixed in base cabinets.
- 6 **TOE KICK** – 5/8" thick x 4-1/2" high industrial grade plywood between end panels. Toe kick is recessed 3-15/16".
- 7 **CROSS SUPPORT STRETCHERS** – 5/8" thick X 4-3/8" deep running the width of the cabinet, with matching edgeband for front face. Additional stretcher positioned beneath drawers for base cabinets only.

DRAWERS – Standard: Nominal 1/2" (12mm) plywood panel front, back, and sides with butt construction. Drawer bottoms are nominal 1/8" (3mm) thick hardboard with maple grain, inserted and glued into dado in front, back and sides.

DRAWER GUIDES – High-quality epoxy coated steel, Cushion-Tec™, side mounted guides, self-adjusting in mounting brackets. Built-in stop, self-closing and stay-closed features with a 100 lb. rated load capacity.

DOVETAIL DRAWER (upgrade only) – Front, back and sides are 5/8" (16mm) thick hardwood with dovetail construction. Drawer bottoms are nominal 1/4" (6mm) thick multi-ply hardwood birch plywood inserted into dado in front, back, and sides, and securely stapled and hot glued.

SOFT-CLOSE SIDE MOUNT, FULL-EXTENSION DRAWER GUIDE (deluxe upgrade with dovetail drawer only) – High-quality steel construction provides full drawer access. Built-in stop, self-closing, and stay closed features with a 100 lb. rated load capacity. Provides soft-close feature that helps reduce drawer slamming. Drawers are full extension, in mounting brackets. Built-in stop.

HINGES – Standard: Heavy-duty, high-quality steel, concealed 6-way adjustable hinge with self-closing feature. Upgrade: Gentle-Touch (soft-close) Hinge: Heavy-duty, high-quality steel, concealed 6-way hinge with soft close resistance.

FINISH – Furniture quality protective finish system on doors, drawer fronts, front frames, and veneer plywood end panels consisting of sanding, stain, catalyzed sealer and catalyzed clear top coats.

Contact your sales representative for information on NAUF options.

NOTICE: The product specifications appearing herein supersede and cancel all previous sheets, supplements and addenda, and represent current manufacturing standards and procedures.

Master WoodCraft Cabinetry reserves the right to make specification changes for continued product improvement.

For aesthetic considerations the furniture and cabinet industries have made veneer on composite panel substrate the standard method of construction for raised panel-in-frame doors in some wood species. Within the Master WoodCraft Cabinetry product line, those species include poplar, north american hardwood, and maple.